



## Level 2/5 Wulumay Close Rozelle NSW

2 2 2

Absolute Waterfront Apartment in the Highly Sought after Balmain Cove Complex with Sun-Filled Northerly Aspect

- Spectacular water views from spacious north facing balcony
- Ducted air-conditioning throughout
- Gourmet kitchen features solid granite benchtops, large pantry & stainless steel appliances including gas cooktop, oven, ducted rangehood, dishwasher
- Light & spacious open plan living and dining areas
- Two well appointed bedrooms feature mirrored built-in wardrobes, direct access onto the balcony & water views. Master features en-suite bathroom
- Separate internal laundry including dryer
- Secure tandem lock-up garage for two cars
- Well maintained strata complex featuring manicured grounds, security access, video intercom, lift access,

**Price** : Leased! \$1,250 per week

**View** : <https://www.balmainrealty.com/1P3446>



**Jo Kennedy**



**Aimee Ryan**  
9818 8888

'THE ESPLANADES' 125/5 WULUMAY CLOSE, ROZELLE

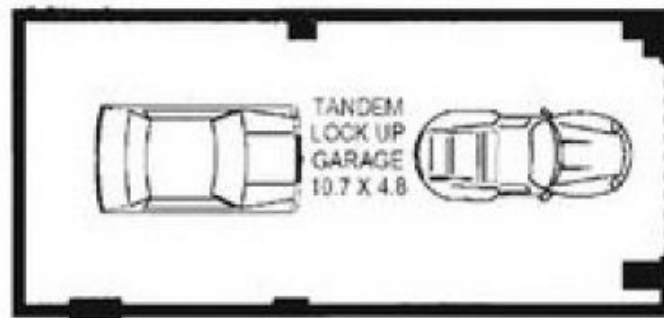

GROUND LEVEL



LEVEL TWO

APPROX GROSS LIVING AREA - 146 SQM GROSS GARAGE AREA - 49 SQM

